

# LITHRONE G37P

*advance*



37" Convertible Perfecting Offset Printing Press

**KOMORI**

## Komori's Lithrone advance series takes offset print production to the next level

The Lithrone G37P advance provides **world-class ROI**\*1

Komori developed the advance series, which offers world-class ROI, in order to improve productivity and profitability for printing companies. In addition to the high return on press investment, advance presses fully support digitalization making the most formidable production press available. Using KP-Connect Pro to link prepress, press and postpress processes optimizes overall production, helping to create smart factories that achieve the highest overall productivity with the least amount of effort. The advance series is all about improving the many micro areas of the process to make a large impact. This is what makes advance series the clear frontrunner in achieving digital transformation for printing companies.

The Lithrone G37P advance is a compact perfecting press that lowers running costs while also economizing on space. The Lithrone G37P advance offers high production, automation and standardization, and is able to meet needs for printing of many different items with short turnarounds and in short runs. Through optimal printing size and double-sided one-pass printing, the Lithrone G37P advance offers world class ROI, particularly for 16-page A4/letter size printing.

\*1 ROI: Return on Investment

\* H-UV, H-UV L ( LED ) and oil-based models available.



## advance × KP-Connect for optimal productivity

According to the data, on average, only 33% of press operating time is spent on production printing\*2.

In conjunction with KP-Connect Pro, the new advance press is able to transform makeready and idle time into production printing.

### Factors that interfere with productivity

Legacy methods of delegating processes and communicating information create downtime, such as waiting for plates or paper

Manually configuring and adjusting settings for items such as feeder and delivery are time consuming

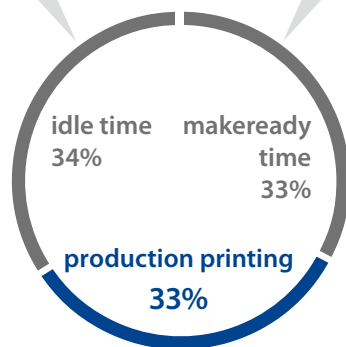

### After introducing KP-Connect Pro and advance presses

#### The KP-Connect advantage

KP-Connect Pro minimizes downtime by **digitalizing the connection between processes**

#### The advance advantage

Advance automates configuration and adjustments, **shortening makeready time**

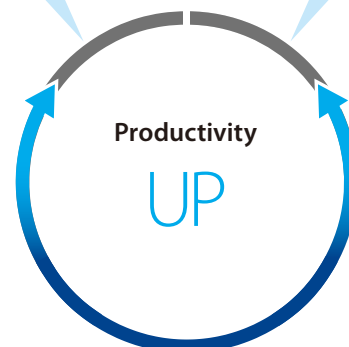

#### The advance advantage

**High-speed, stable operation** through improved paper feeding and delivery also increases productivity while production printing

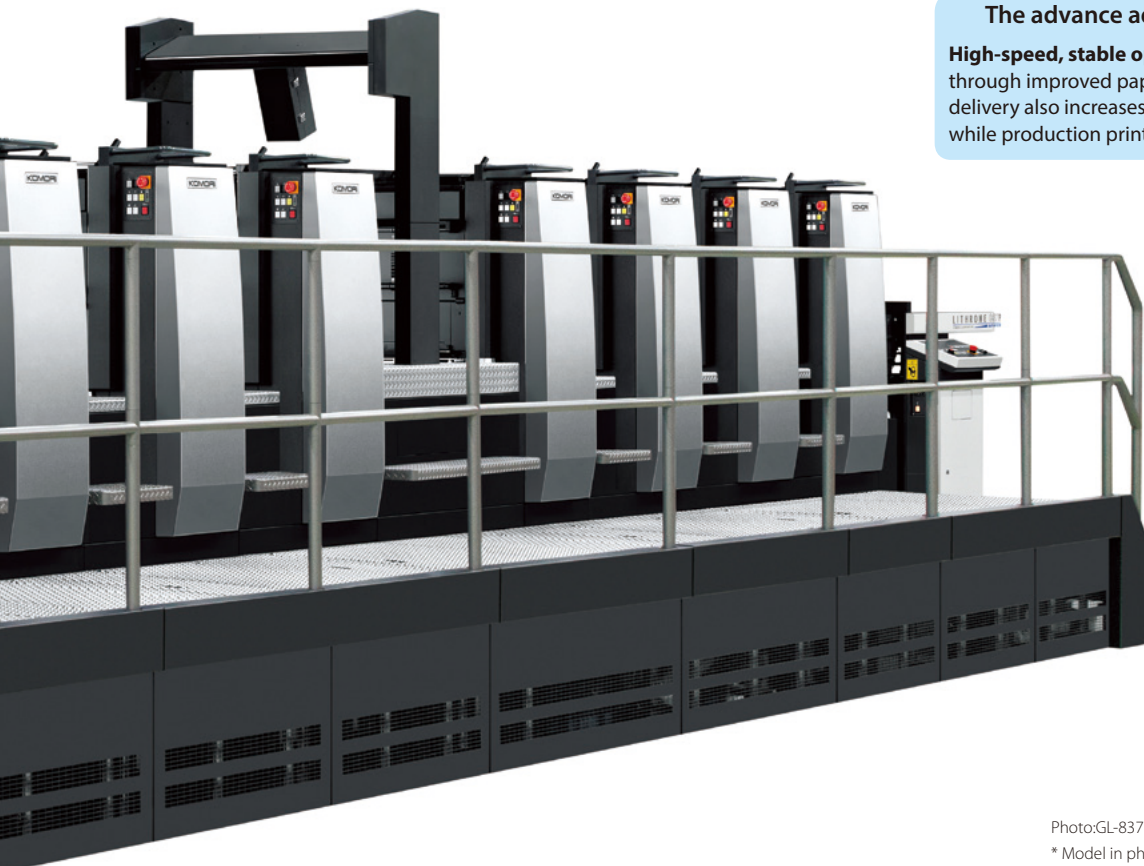

Photo:GL-837P-A

\* Model in photograph includes optional specifications.

\*2 In-house survey Of the 45 companies that use the KHS-AI (51 machines), results were calculated from 31 companies that mainly use four colors and exclude package users.

# Creating smart factories using CONNECTED AUTOMATION

The digital transformation is sweeping the print industry. Through Connected Automation will print providers be able to take advantage and arrive at the new smart factory model. Komori's key to Connected Automation and achieving the smart factory model is through use of Komori's KP-Connect Pro. KP-Connect Pro software enables unified management of a range of devices and information, to better maximize productivity.

## Three advantages of advance presses and KP-Connect Pro

### Visualization

#### Link production processes and monitor operations

- Print room operating status can be checked in real-time, even when off-site
- Operators can grasp the progress of connected processes and status of important materials such as plates and paper, for more efficient makeready
- Automatically create a variety of reports, using actual results data, helping to improve productivity



### Automation

#### Automatic job linking between prepress, press and postpress

- Job information from the scheduler is automatically carried over to the press, reducing time spent on configuring complex settings
- Print operators can specify automatic output of printing plates without stopping production\*1

\*1 Conditions may apply in regard to compatible manufacturers.



### Optimization

#### Digitalization of process management, for optimization overall production

- Shifting from analogue methods (such as job tickets) to digitalization greatly reduces time spent on process management
- Automatically scheduling optimal job order, with less time spent on makeready and arrangements, for instance by prioritizing fast turnaround jobs, or grouping together jobs that use the same ink or paper size



## KP-Connect Komori Solution Cloud

### KP-Connect Basic

#### Monitor operations remotely, anytime, anywhere

KP-Connect visually analyzes and graphs real print operation data, helping to improve productivity.

### KP-Connect Pro

#### Links all devices, to visualize and optimize entire site

Monitor progress of all jobs in realtime, at a glance, including prepress, press and postpress. Connected Automation, including MIS and production scheduling, increases overall site efficiency.

## advance presses offer high ROI

ROI is the lifeblood of printing companies, and the advance series of presses is dedicated to providing world-class ROI. Komori achieves this high ROI by focusing on three areas.

$$\text{ROI Return on Investment} = \frac{\text{Return Profit } (\hat{=} \text{Productivity})}{\text{Investment Capital investment } (\hat{=} \text{Initial investment} + \text{maintenance costs})}$$

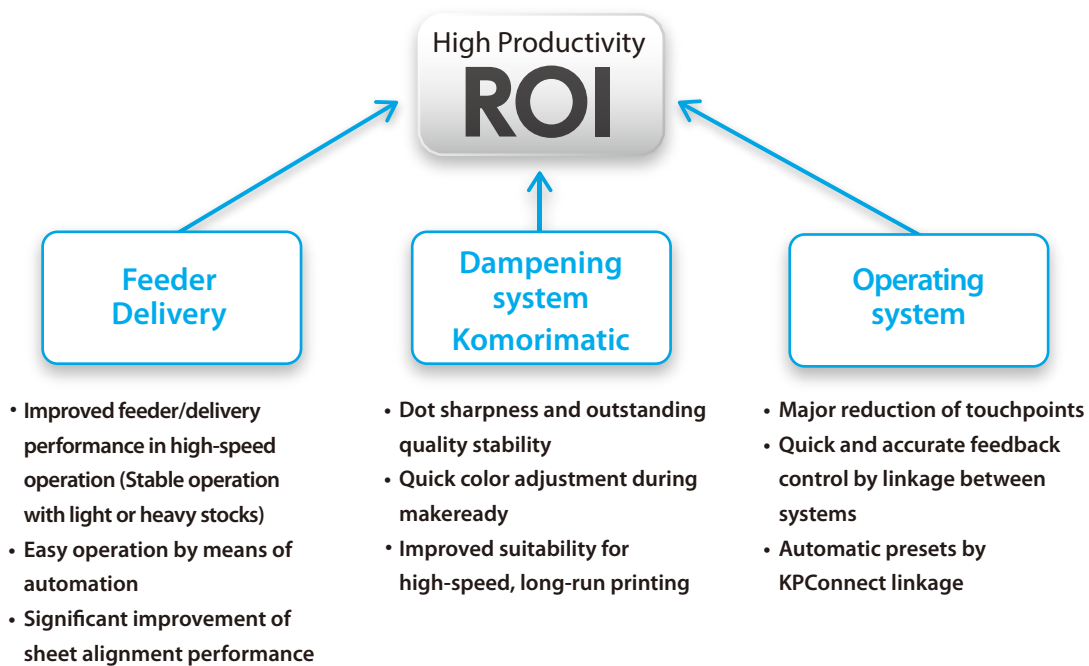

### Reasons for increased production efficiency

Improved paper feed and delivery allow for shorter production printing time when printing speed is increased. Additionally, shorter makeready time allows for more jobs to be handled in the same amount of time. Improved production efficiency allows for downsizing, for instance by handling jobs previously carried out on three presses on two presses instead, thus increasing productivity.

Additionally, shorter makeready time allows for more jobs within a given timeframe.

\* Run length is the same

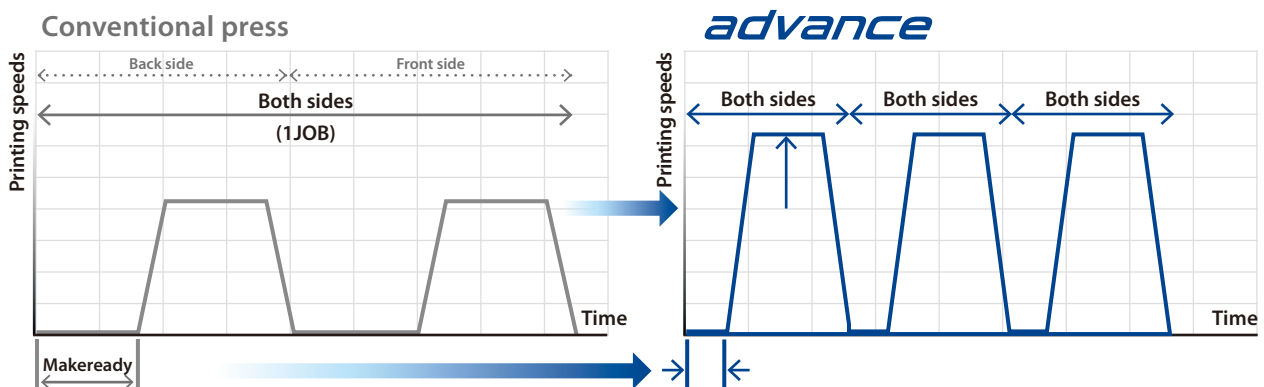

# Superior performance creates significant profits

Improving productivity while staying cost-competitive in cut-throat markets, and carving out new markets by offering superior services, both require flexible, multi-functional presses capable of sophisticated automation. The Lithrone G37P advance does just that by incorporating Komori's world class advance series automation features and systems that reduce operator workload while increasing productivity.



## Allows a color bar on 8-up A4 impositions even on double-sided prints

### Back side (pre-printing), center color bars

The maximum printing area of 620 mm x 930 mm accommodates simultaneous printing of a color bar with 8-up A4. The press' color bar scanner is equipped with a tracking sensor function, so center color bars\*1 can be scanned automatically along with register marks for automatic color registration. The Lithrone G37P advance enables imposition for both front and back sides in the same manner as a single-sided press.

\*1 Center color bar is compatible when equipped with H-UV/H-UV L (LED).

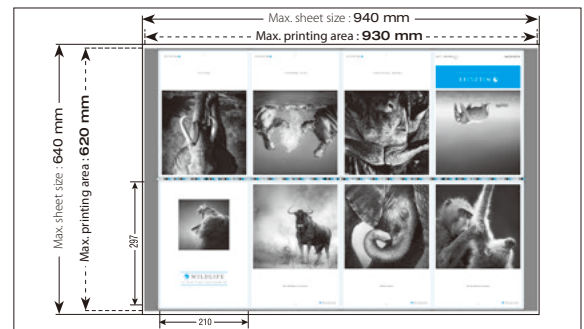

## Optimal transfer paths due to highly stable perfecting mechanism

### Perfecting mechanism

A simple double-double-single, gripper-based perfecting mechanism, and transfer/suction/perfecting cylinder structure, ensures a stable sheet path even during double-sided printing, with minimal scuffing and marking. The new design also helps reduce maintenance.

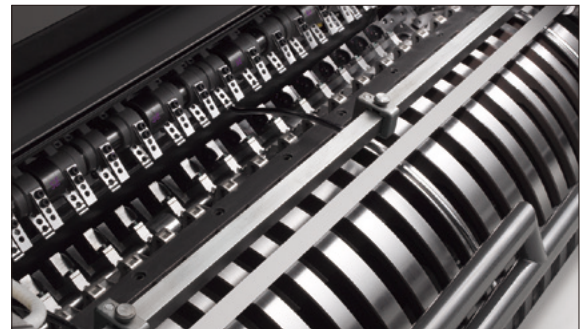

## Dramatically increases productivity by shortening cleaning and makeready times

### Automatic cleaning programs

Blanket washing, along with impression cylinder and ink roller cleaning, are fully automated and initiated with just the touch of a button. For blanket washing and impression cylinder cleaning, the impregnated cloth cleans more effectively, not only shortening cleaning times but reducing the amount of cloth consumed. Cleaning protocols are preset, increasing productivity, increasing efficiency and drastically decreasing total makeready time.

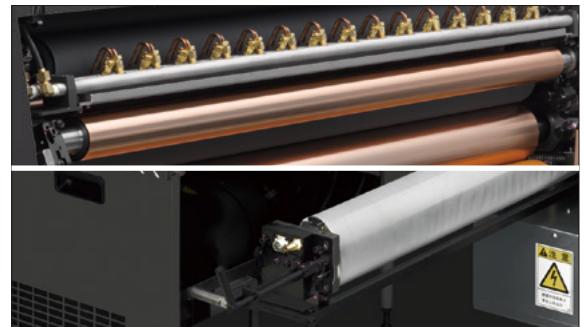

## Eliminates need for burdensome plate tail-edge bending

### Benderless clamp

Benderless clamps streamline plate preparation. The flat plate clamping also improves plate registration accuracy and reduces preparation time. Additionally, storing plates for reprints is much easier without a tail bend, making reprint orders easy to handle.

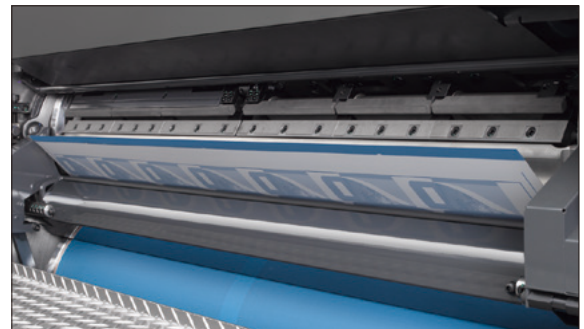

## A compact, high-performance space-saving press

The Lithrone G37P advance is an energy-saving, double-sided 8-color press with a compact design that is perfect for use in where space is limited.

\* Includes optional features.

\* Use the 2D barcodes on pp. 12-13 to view video of each feature.

## Equipped with a variety of features for stable, high-speed production

High-performance paper feed and delivery is indispensable for more productive, high-speed operation. The Lithrone G37P advance is equipped with a range of unique Komori technologies, including sucker box that ensures stable paper feed, air blower and wire guides to reduce scuffing and marking and improve transfer, and the latest paper alignment systems. Stable operation dramatically increases productivity and helps reduce operator workload. The Komorimatic dampening system achieves stable water control quickly, shortening makeready times, maintaining stability and reducing paper waste.

\* H-UV, H-UV L ( LED ) and oil-based models available.





## Automatically adjust optimal feeder air levels

### Simple air presets **New**

Presetting feeder and registration air levels allows optimal air levels to be adjusted at the touch of a button. This makes adjusting air levels for different types of paper, ensuring even inexperienced operators can efficiently load paper.



## Paper feeding that enables high-speed printing regardless of paper type

### Sucker box

A redesigned pump layout ensures sufficient air to stably separate even maximum size sheets during high-speed printing. The system is designed for a wide range of stocks.

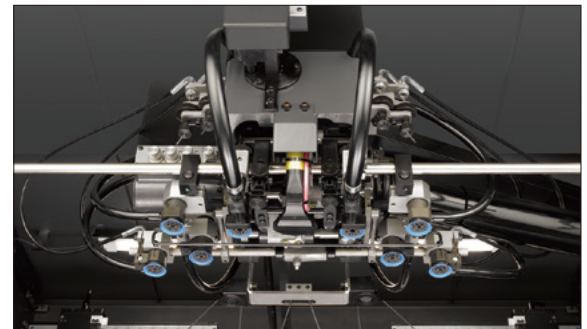

## Transfer systems for stable feeding and delivery

### Air side lay **1**

The vacuum style side-lay maintains stable register accuracy without the use of rollers, preventing marking and smearing.

### Suction-based tape feeder **2**

Eight bar-type rollers improve operability, ensuring stable paper feed even during high-speed operation.

### Gripper bar **3**

Gripper bars, developed using in-depth air simulations, ensure excellent sheet alignment.

### Sheet travel belt/belt suction wheel (oil-based models) **4**

A paper transfer that utilizes a synchronized belt (matching the surface speed of the paper) and suction wheel that improves paper alignment, ensures stable, high-quality paper delivery.

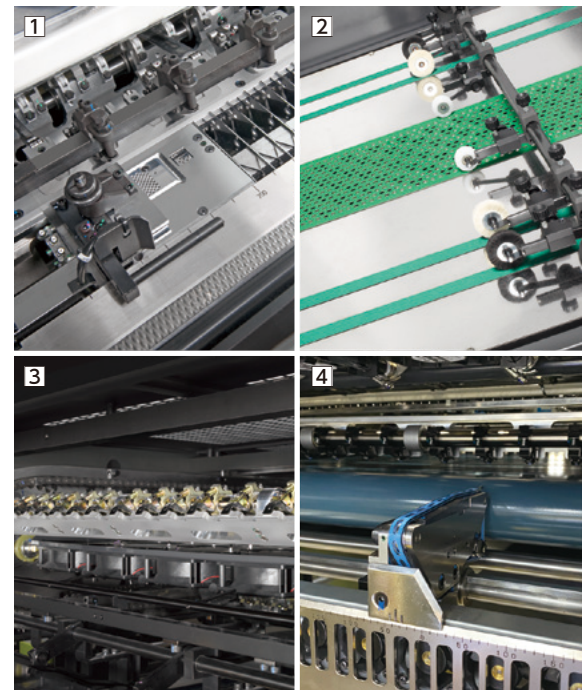

## Stable, high quality with Komori's unique dampening system

### Komorimatic **Unique**

A uniform water layer helps minimize color inconsistencies. The system offers sharp dots and fast color acquisition, with increased effectiveness for high-speed long runs.



**New** : New feature **Unique** : A unique Komori feature. Applies to following pages.

\* Includes optional features.

\* Use the 2D barcodes on pp. 12-13 to view video of each feature.

# Supports digitalization.

## Unique Komori systems drastically reduce operator workload

KHS-AI is an integrated, self-learning control system that fully supports operators, from job start-up to production printing, reducing makeready time and paper waste. Furthermore, connecting to KP-Connect allows production information to be shared digitally, helping to optimize production. All color measurement and control devices are originally developed by Komori. Synergy between reliable production (such as ink keys with high accuracy and followability) and systems ensure faster color and registration adjustment and dramatically shorter makeready times. The systems also provide swift and accurate automatic feedback, freeing operators from time-consuming in-run adjustments.

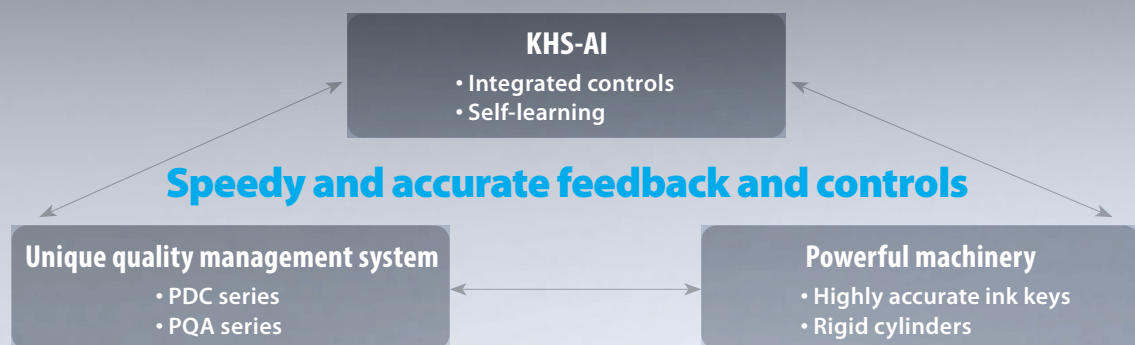

### Simple, one-screen operation, for ease of use

#### KHS-AI, ease of use New

During job registration, makeready and production printing, all necessary information for each phase is gathered onto a single screen. Adjustments can be made during production printing while monitoring registration, ink and dampening. The number of touches required to switch screens has also been reduced, shortening configuration time and helping to prevent human error. Additionally, job settings can be automated via KP-Connect Pro, reducing configuration time by approximately 85% compared to previously.

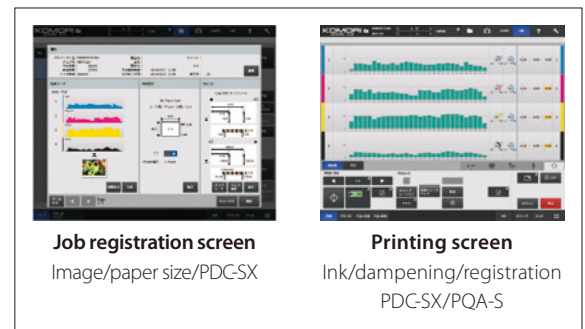

### More efficient makeready through self-learning

#### KHS-AI, high precision preset function Unique

Ink key adjustments, air levels and print register can be automatically preset according to paper size and stock information taken from job data, greatly reducing makeready time. Self-learning tools are also installed to update data with each use, further fine-tuning presets.

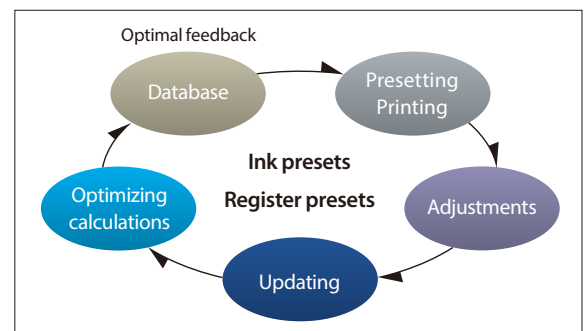

### Machine-regulated density, saves on time and paper

#### KHS-AI, smart feedback feature Unique

A unique Komori feature that provides quick feedback when density levels differ from target density, and is capable of responding even to initial falloffs in density. Density is measured with PDC-SX, and the amount of ink applied to the roller is then adjusted based on any calculated excess or shortcomings. These unique ink fountain controls can re-adjust to target density within around 30 sheets, dramatically reducing paper waste.

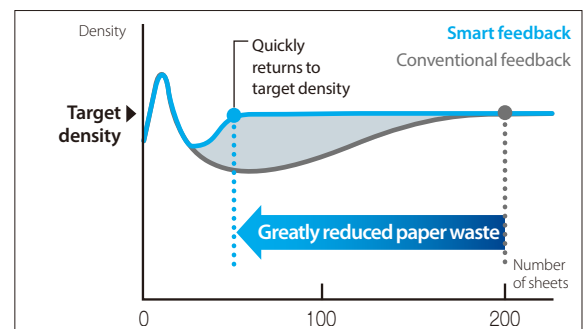

### Automatic color and register controls, with no need for a loupe

#### PDC-SX (Spectral Density Control) Unique

PDC-SX not only measures color but also registration, feeding results back to the press. This also applies to register on the back of the sheet. This reduces wasted time, workload and paper when registration does not match.

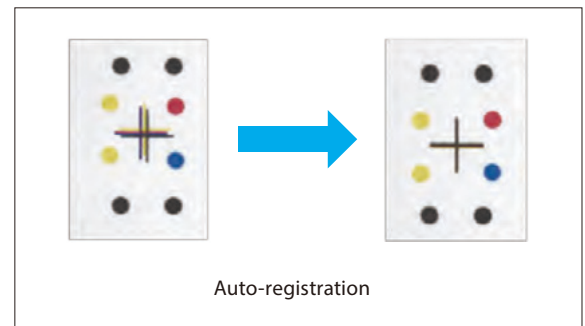

### Operator-free quality while printing

#### PQA-S V5 (In-line Print Quality Assessment System for Sheetfed) Unique

**Quality inspection:** Checks for printing problems and prevents misprints from passing to postpress

**Color control:** Measures color bar and automatically adjusts to match and maintain target density

**Automatic register control:** Measures dedicated registration marks to automatically adjust for and maintain unit-to-unit registration

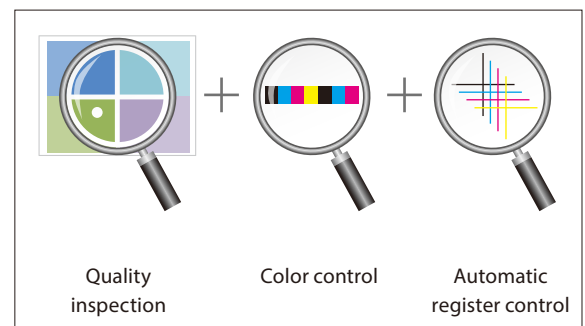

\* Includes optional features.

\* Figures show Komori measurements under specific conditions. No warranty is implied.

\* Use the 2D barcodes on pp. 12-13 to view video of each feature.

# Functionality to meet a wide range of needs and further increase ROI

The advance presses offer a wide line-up of features to increase ROI, making them perfect for commercial and publishing.

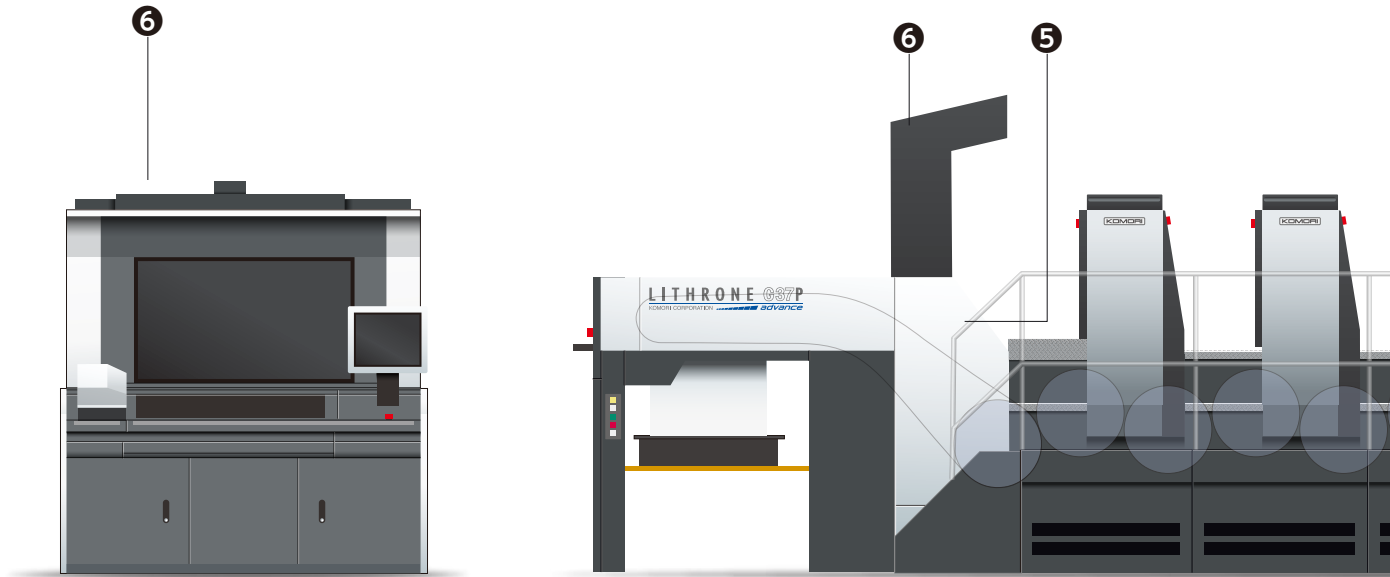

## ⑥ Quality control

A variety of systems to drastically increase productivity.

All uniquely developed by Komori, these systems allow for quick and highly accurate register and color matching and maintain quality during production printing.



- **KHS AI** KHS-AI ● ● ●
- **PDC-SX** Spectral Print Density Control-SX ● ● ●
- **PDF comparator system** ● ●
- **PQA-S V5** Print Quality Assessment System (Sheet) V5 ● ●
- ① **Quality inspection**
- ② **Quality inspection + color control**
- ③ **Quality inspection + color control + automatic register control**
- **Automatic mask creation** ●
- **Sheet numbering system** ●
- **KID** Komori Info-Service Display ● ●

## ⑤ Dryer

Komori's unique drying system, combines ecology, economy, quality and reliability.



- **H-UV** ● ● ●
- **H-UV L (LED)** ● ● ●

\*URL for above QR codes: <https://komorisolutions.com/video/en/g37pa.html>

- ... High-speed printing
- ... Short makeready
- ... Quality
- ... Reduced paper waste
- ... Environment/safety

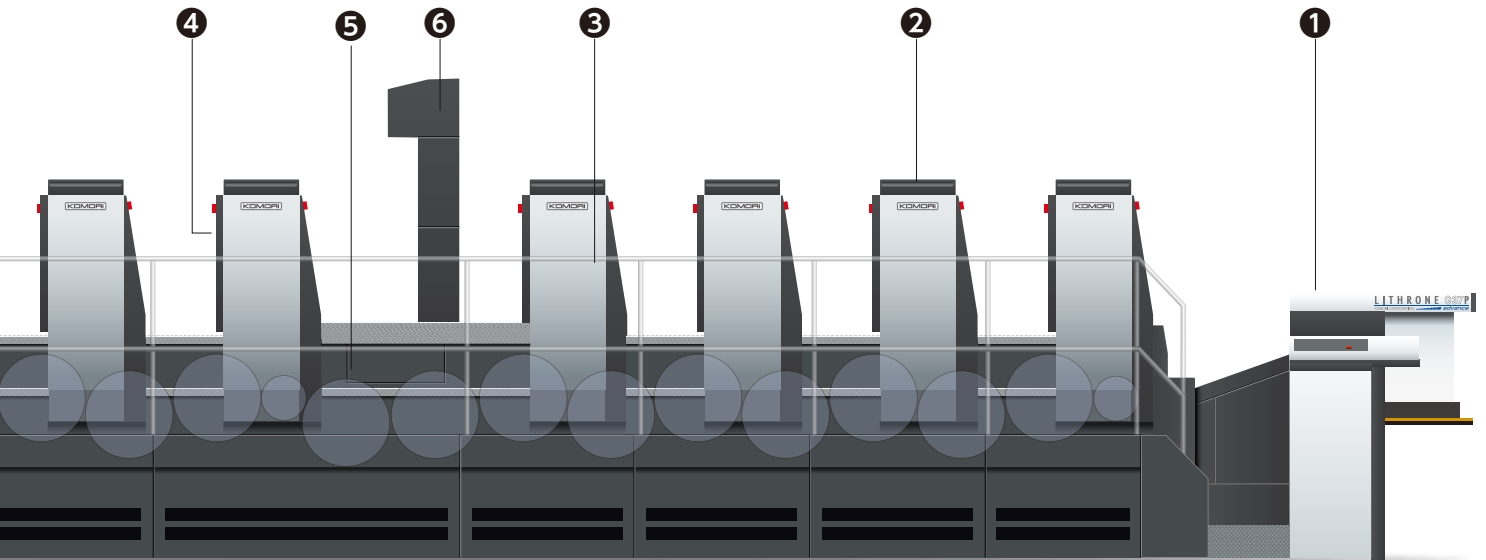

### 3 Automatic Washing/Cleaning System

Efficient automatic washing/cleaning by means of an automatic control program.

Use of pre-soaked cloth for automatic blanket washing and automatic impression cylinder cleaning shortens cleaning time and reduces cloth consumption, making it friendlier on the environment.



- Automatic blanket washing ● ●
- Automatic impression cylinder cleaning ● ●
- Automatic ink roller cleaning ●

### 1 Feeder

Automates paper settings and adjustments during printing.

Easy to operate and assists stable, high-speed printing on thick or thin paper.



- Manual non-stop feeder system ● ●
- Sucker box ●
- Front lay ●
- Simple air presets ●

### 4 Plate changing system

Uses a benderless clamping mechanism, for more efficient plate changing without the need for plate tail-edge bending. The line-up includes semi-APC (semi-automatic), full-APC (fully automatic) and A-APC (which allows plates to be changed for all colors at once in 1 minute and 25 seconds).



- Semi-APC Automatic Plate Changer ●
- Full-APC Fully Automatic Plate Changer ●
- A-APC Asynchronous Automatic Plate Changer ●

### 2 Unit/other

Includes a system to prevent UV ink mist from scattering, for increased environmental friendliness. DC blowers also help to reduce power consumption and heat levels.



- Komorimatic ● ● ●
- A-APC/Asynchronous Automatic Plate Changer ●
- Ink mist extractor fans ●
- DC blower ●

\* Restrictions apply regarding availability on different models and available combinations of features.

\* Figures show Komori measurements under specific conditions. No warranty is implied.

# Two cutting-edge systems to transform production

With increased demand for short run jobs and fast turnaround times, minimizing press make-ready time and maximizing production print time has become key for improving profitability. Komori provides two systems to minimize make-ready time: Parallel Makeready, which drastically shortens changeover time by simultaneously carrying out multiple processes, and Autopilot, which streamlines human work through the power of automation.

## Greatly shorten the time required to job changeover

### Parallel Makeready

Plate changing, blanket washing, pre-inking and air/register presetting can all be carried out simultaneously with the press of a button. Parallel Makeready can also be combined with faster color startup via the KHS-AI to reach production printing as quickly as possible. This greatly reduces makeready times and significantly contributes to improved ROI. The more job changes required for short runs, the more Parallel Makeready's advantage becomes apparent, streamlining operator work-load.

### Shorten makeready time

The graph below shows the Lithrone G37P advance (37" 8-color double-sided press with KHS AI) compared to other systems.

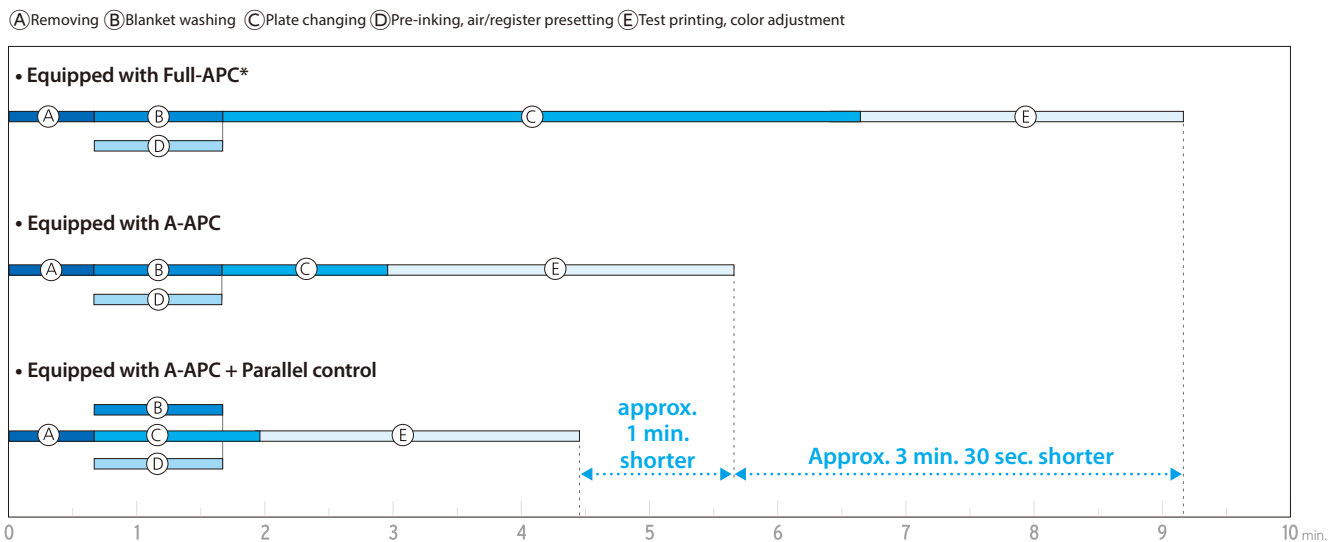

## Change plates simultaneously in minimal time, regardless of number of colors

### A-APC (Asynchronous Automatic Plate Changer)

The A-APC carries out fully automated, simultaneous, multi-color plate changes, greatly reducing non-productive time and increasing efficiency.



## Examples of custom setups/major applications

### LITHRONE G37P advance (37-inch offset printing press with perfector)

■ H-UV L (LED)

#### General commercial printing/publishing:

Oil-based model (example setup: GL-837P-A [4/4])

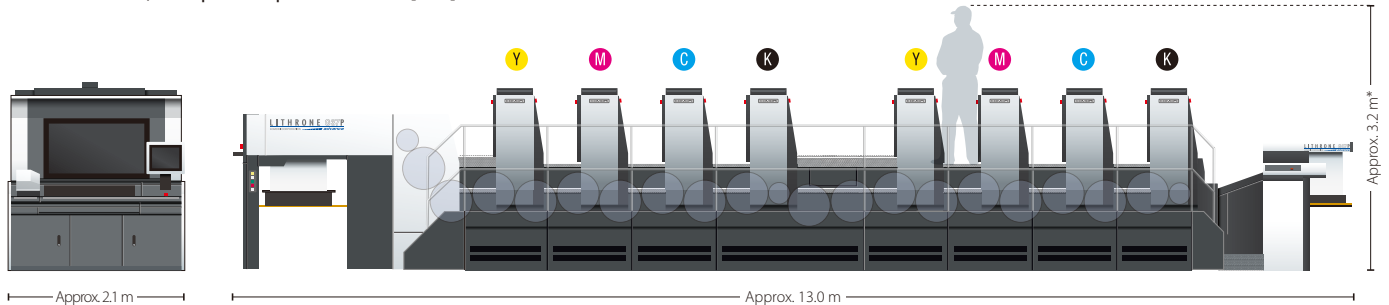

#### General commercial printing/publishing:

H-UV L (LED) model (example setup: GL-837P-A [4/4])

Print quality inspection + color control + automatic register control

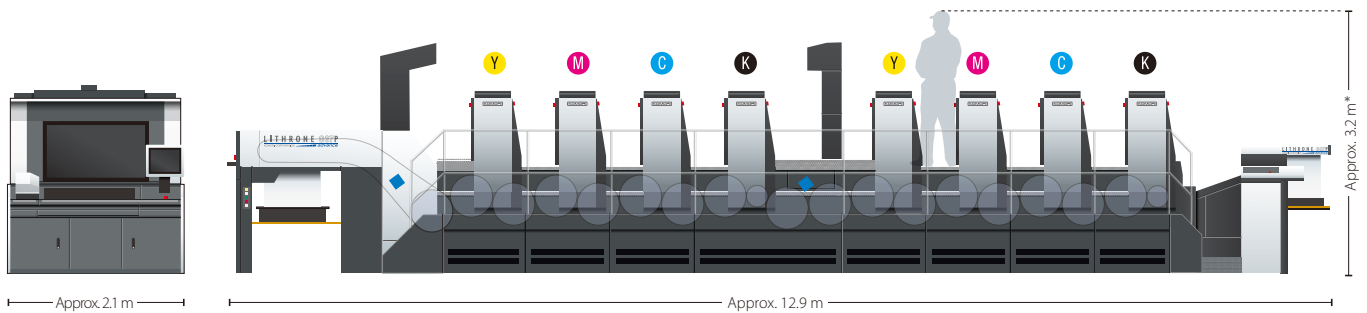

\* Assuming a standing, 180 cm tall operator. For machine dimensions, see specifications below.

\* Additional workspace, not included in machine dimensions, is required for installation, such as for surrounding equipment/cabinets and paper transport

## Specifications

LITHRONE G37P advance (37"Convertible Perfecting Offset Printing Press) specifications			
Model		GL-837P-A	
Number of colors		8	
Max. printing speed	sph	15,000	
Max. sheet size	mm(in)	640 × 940 (25.2 × 37)	
Min. sheet size	mm(in)	297 × 420 (11.7 × 16.5) (350 × 420 (13.8 × 16.5) Reverse)	
Max. printing area	mm(in)	620 × 930 (24.4 × 36.6) (620 × 916 (24.4 × 36.1) Oil-based reverse)	
Sheet thickness range	mm(in)	0.04 - 0.45 (0.0016 - 0.018)	
Plate size	mm(in)	700 × 945 (27.6 × 37.2)	
Blanket size	mm(in)	780 × 955 (30.7 × 37.6) [including aluminum bar]	
Feeder pile height	mm(in)	1,100 (43.3) (900 (35.4) without plinth)	
Delivery pile height	mm(in)	1,100 (43.3) (900 (35.4) without plinth)	
Dimensions	Length (L)*1	mm(ft)	12,829 (42'1") (13,011 (42'8") conventional ink-based specification)
	Width (W)	mm(ft)	3,471 (11'5") (3,419 (11'3") without plinth)
	Height (H)	mm(ft)	2,161 (7'1") [2,436 (7'12") with safety cover open ] 1,961 (6'5") (2,236 (7'4") without plinth, with safety covers open)

\* When performing two-sided printing using oil-based ink, a margin is required on the back of the sheet for the suction wheel.

\* Maximum printing speed may differ depending on chosen specifications and printing conditions.

\* Performance and values may differ depending on specifications. Specifications are also subject to change due to product improvements or other reasons.

Note:

Komori reserves the right to change specifications on machines without notice to improve reliability, functionality or design. Komori carries no obligation for use that does not correspond to the standard safety measures for products noted herein and other precautions. The technical information in this catalog constitutes an explanation of the general operations of the product and grants no rights or license belonging to Komori Corporation or third parties. The photographs in this catalog include some special specifications. Specifications are current as of November 2022. Specifications and photographs are subject to change at a later date due to product improvements.

---

## KOMORI CORPORATION

11-1, Azumabashi 3-chome, Sumida-ku, Tokyo 130-8666, Japan Tel: +81-3-5608-7817~19 Fax: +81-3-3624-6955

<https://www.komori.com>



JQA - QM3657  
JQA - EM3213  
Komori Machinery Co., Ltd.